

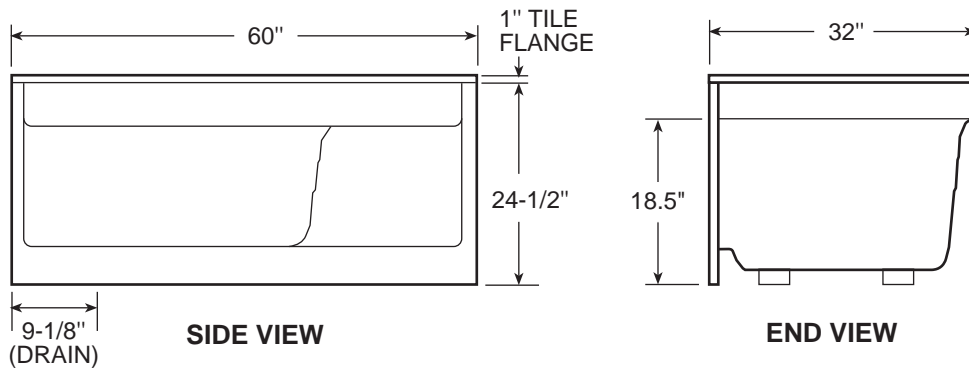

60 X 32 Shower Base With Integral Seat INSTALLATION INSTRUCTIONS

From the ground up, Jacuzzi Whirlpool Bath shower bases are the foundation of a well-designed bathroom. They are fashioned of high gloss acrylic in dramatic colors. From the luxurious height, to the decorative slip-resistant surface, our shower bases combine European styling and state-of-the-art quality.



SPECIFICATIONS

DIMENSIONS	FLOOR LOADING	PRODUCT WEIGHT
60" (1524 mm) L	27 lb/sq. ft.	55 lb
32" (813 mm) W	(132 kg/sq. m)	(25 kg)
24-1/2" (622 mm) H		

Use liquid detergent to maintain bright, smooth surface.
Do not use abrasive household cleaners.

Product specifications are subject to change without notice.

Important: Read complete instructions before beginning installation.

Each shower base is shipped with a drain and stainless steel strainer. An optional bright brass strainer is available for installation on the drain assembly.

Remove the shower base from the carton. **Do not destroy the shipping carton until after satisfactory inspection of the product.**

Immediately upon receipt, inspect the base before installing. Should inspection reveal any damage or defect in the finish, do not install the base. Damage or defect to the finish claimed after the base is installed is excluded from the warranty. Jacuzzi Whirlpool Bath's responsibility for shipping damage ceases upon delivery of the products in good order to the carrier. Refer any claims for damage to the carrier. For definitions of warranty coverage and limitations, refer to the published warranty information packaged with the product. Jacuzzi Whirlpool Bath is not responsible for any defect that could have been discovered, repaired, or avoided by following this inspection and testing procedure.

Plan the installation in relation to the finished wall surfaces. Take into account the dimensions of both the shower base and the shower door enclosure to be used with it.

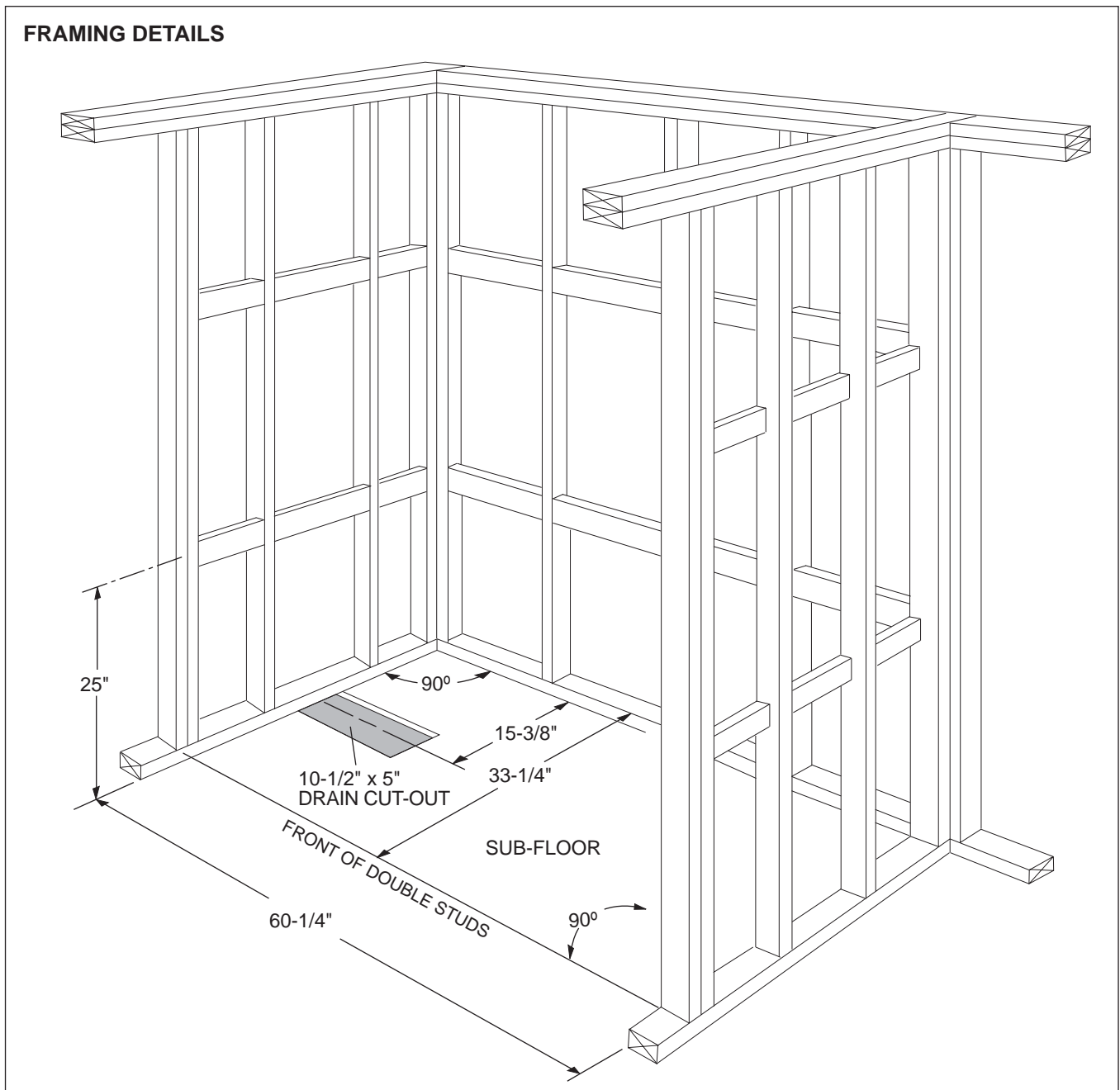

Framing and Support

The unit must be supported from the bottom and **not** from the nailing flange. If the subfloor is level, no other preparation is necessary. You can proceed to install the bath. If the subfloor is not level, you **MUST** level the entire surface prior to installing the bath. The use of materials that shim or provide a level installation are allowed provided the method used will insure a level unit that is supported from the bottom. Materials that may be used are a floor leveling compound, mortar, plaster or minimal expansion structural foam having a density of a minimum of 5 lbs./cubic ft; however the unit must remain level in order for it to drain properly and the foam feet must make full contact with the leveling material. Both sides of a joint or splice of subfloor should be level to each other. **When attaching baths with flanges to stud wall, use shims to fill any gaps between the bath flange and studs.**

The shower base should be installed after construction of the studwall and after rough plumbing is in place.

It is important that the framed pocket be plumb and square and that the framing members be located as detailed in the framing illustration. If the shower base unit is to be installed in an existing shower room studwall,

additional studs must be added to the dimensions shown.

Installation

Remove the stainless steel strainer from the drain assembly. Disassemble the locknut and two gaskets from the back of the drain assembly. Apply a 1/4" bead of caulking (silicone) to the drain hole and insert the drain assembly. Replace the rubber washer, fiber washer, and lock nut in that order. Hand tighten the locknut. Remove excess sealant from finished side.

Apply a lubricant (common household liquid soap works well) to the inside of the rubber seal of the drain assembly.

NOTE: Watertight installation of the drain is the installer's responsibility. Drain leakage is excluded from the Jacuzzi Whirlpool Bath warranty of this product.

Slide the shower base into the framed opening and attach the shower base flange to the stud wall and blocking with drywall screws.

NOTE: If there is any gap between base flange and stud or blocking, shims MUST be used to prevent distortion or cracking of the flange.

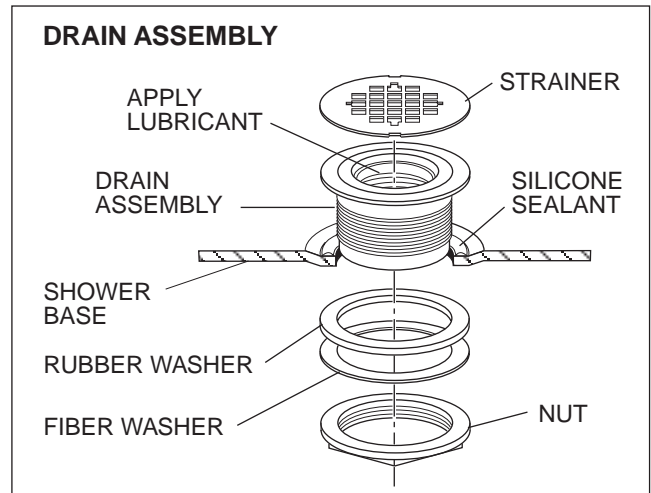

FLANGE MOUNTING

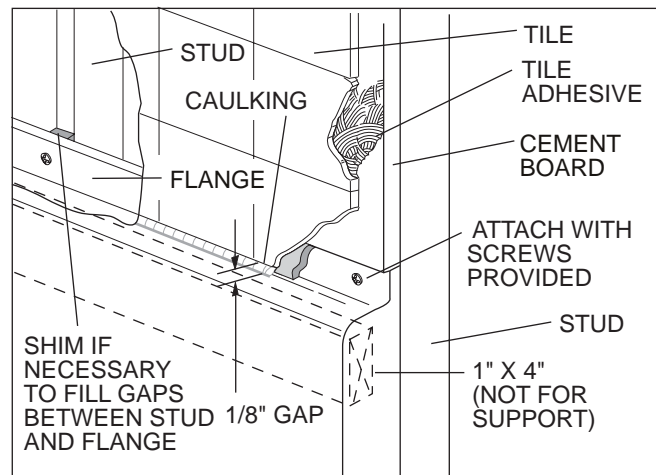

With a large screwdriver and the tool included with the drain, tighten the inside compression nut to seal the drain pipe connection. After drain is fully installed, test for proper drainage. If the shower base does not drain properly, rectify this condition before proceeding with the installation. **Jacuzzi Whirlpool Bath is not responsible for removal and/or reinstallation costs.**

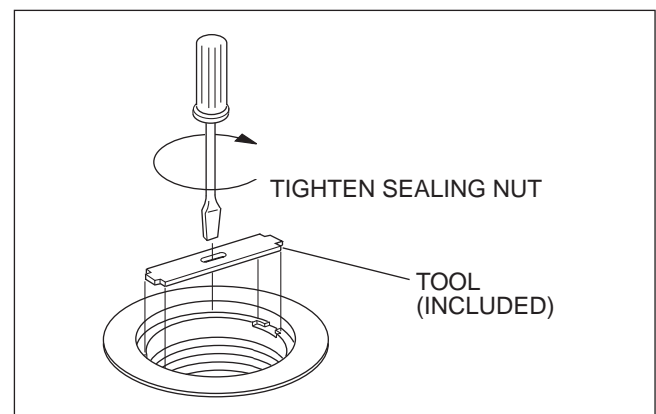

To install shower doors, it is necessary to make the tile walls flush with the vertical wall of the unit. This can be accomplished by two recommended methods. In Method #1, furring strips (a 1x4 may be sufficient) are applied to the framing studs with the cement board and tile as shown below. This is done for all three walls of the shower enclosure. In Method #2, a mounting surface is built out flush with the vertical wall of the unit and the same width as the base threshold as shown below.

RECOMMENDED METHOD 1

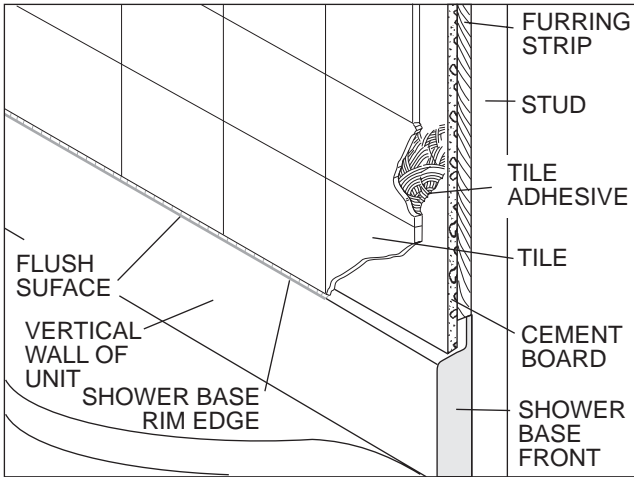

RECOMMENDED METHOD 2

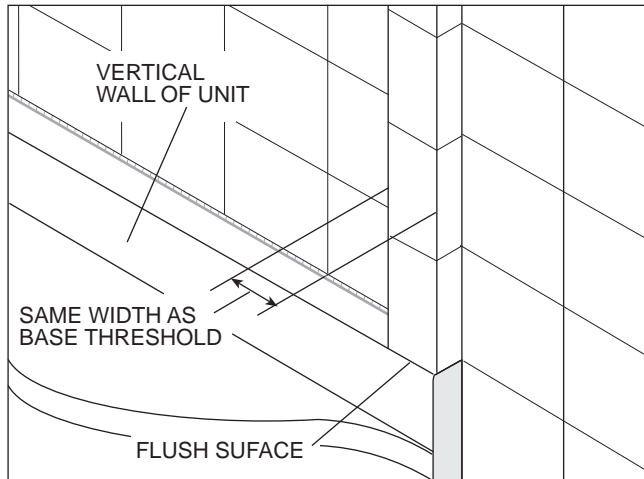

Water Supply

Consult local authorities for plumbing code requirements in your area.

IMPORTANT: Jacuzzi Whirlpool Shower base base does not warrant connections of water supply fittings and piping or drain/overflow systems. Nor is it responsible for damage to the shower base which occurs during any installation procedure.

Clean-Up After Installation

To avoid dulling and scratching the surface of the shower base, never use abrasive cleaners. A mild liquid detergent and warm water will clean soiled surfaces.

Remove spilled plaster with a wood or plastic edge. Metal tools will scratch the surface. Spots left by plaster or grout can be removed if lightly rubbed with detergent on a damp cloth or sponge.

Paint, tar, or other difficult stains can be removed with paint thinner, turpentine, or isopropyl alcohol (rubbing alcohol).

Minor scratches which do not penetrate the color finish can be removed by lightly sanding with 600-grit wet/dry sandpaper. You can restore the glossy finish to the acrylic surface of the shower base base with a special compound, Meguiar's #10 Mirror Glaze. If that is not available, use automotive rubbing compound followed by an application of automotive paste wax.

Major scratches and gouges which penetrate the acrylic surface will require refinishing. Ask your Jacuzzi Whirlpool Shower base base dealer for special instructions.

**PRODUCT SPECIFICATIONS ARE SUBJECT TO CHANGE WITHOUT NOTICE.
USE INSTALLATION INSTRUCTIONS SUPPLIED WITH PRODUCT.**

Jacuzzi Whirlpool Shower base base has obtained applicable code (standards) listings generally available on a national basis for products of this type. It is the responsibility of the installer/owner to determine specific local code compliance prior to installation of the product. Jacuzzi Whirlpool Shower base base makes no representation or warranty regarding, and will not be responsible for any code compliance.

Jacuzzi Whirlpool Shower
P.O. 702168, Dallas, TX 75370-2168
Service Support: Call (800) 288-4002

©1998 Jacuzzi Whirlpool Bath N66000 8/13/04



Printed on Recycled Paper

Printed in the U.S.A.

Jacuzzi Whirlpool Bath Limited Warranty Builder Group Bath Product

WARRANTY COVERAGE

Jacuzzi Whirlpool Bath (the "Company") offers the following express limited warranty to the original purchaser of any Jacuzzi Whirlpool Bath Builder Group Bath Product ("unit") who purchases the product for personal or single family use ("user"). The Company will repair or replace, at its option, the unit or its equipment in accordance with the following terms and conditions.

ONE YEAR LIMITED WARRANTY ON BATHS

Our limited warranty on Builder Group Bath products is for one (1) year. Our warranty covers the unit and factory-installed components (e.g., pump, motor) against defects in material or workmanship. Warranty coverage begins on the date the unit was originally purchased by the user.

NINETY DAY (PARTS ONLY) LIMITED WARRANTY ON OPTIONS AND ACCESSORIES

Our limited warranty on options and accessories manufactured by the Company is for ninety (90) days for parts only. Our warranty covers options and accessories manufactured by the Company (e.g., fill spout kits, trim kits, skirts) against defects in material or workmanship. Warranty coverage begins on the date the option or accessory was originally purchased by the user.

WARRANTY LIMITATIONS

Our limited warranty does not cover defects, damage, or failure caused by the common carrier, installer, user, or other person, or resulting from, without limitation, any of the following: careless handling (lifting unit by plumbing, abrading finish, etc.) including its own negligence; modification of any type for any reason (including modification to meet local codes); improper installation (including installation not in accordance with instructions and specifications provided with the unit); connections supplied by the installer of the equipment; improper voltage supply or unauthorized electrical modification; misuse; incorrect operation, or lack of proper routine maintenance; operation of the unit without specified minimum amount of water or at inappropriate water temperature; use of abrasive or improper cleaners; or acts of God, such as lightning, floods, earthquakes, etc.

In addition, THE COMPANY WILL NOT BE RESPONSIBLE FOR INCIDENTAL OR CONSEQUENTIAL DAMAGES or losses arising from any cause (e.g., water damage to carpet, ceiling, loss of use, etc.) including its own negligence; damages to, respecting, or resulting from: plated parts when pool and/or spa chemicals are used in the unit; optional bath equipment not manufactured by the Company, supplied by Dealer, installer or the Company; the unit's prior usage as an operational display; or defects that should have been discovered before installation. This limited warranty does not include: labor, transportation, or other costs incurred in the removal and/or reinstallation of the original unit and/or installation of a replacement unit; any costs relating to obtaining access for repair; or loss of use damage, including loss of sales, profit or business advantage of any kind under any circumstances. Bath units are excluded from any warranty coverage if any addition, deletion, or modification of any kind whatsoever has been made to the unit (or to any component).

Warranty coverage is provided in the United States of America and Canada.

EXCLUSION OF IMPLIED WARRANTIES

IMPLIED WARRANTIES OF MERCHANTABILITY AND FITNESS FOR A PARTICULAR PURPOSE ARE DISCLAIMED ALTOGETHER OR TO THE FULL EXTENT ALLOWED BY LAW.

NOTICE: This warranty gives you specific legal rights, and you may also have other rights which vary from state to state. There are no warranties applicable to Jacuzzi Whirlpool Bath products except as expressly stated herein or as implied by applicable state and federal laws. The Company will not be responsible for any statements or representations made in any form that go beyond, are broader than or are inconsistent with any authorized literature or specifications furnished by the Company.

Some states do not allow limitations on how long an implied warranty lasts, or the exclusion or limitation of incidental or consequential damages, so the above limitations and exclusions may not apply to you.

RETURN OF WARRANTY CARD

The attached Warranty Registration Card MUST be filled out by the purchaser within thirty (30) days from purchase and mailed to Jacuzzi Whirlpool Bath in order for this warranty to become effective.



Jacuzzi Whirlpool Bath
P.O. 702168
Dallas, TX 75370-2168

RESPONSIBILITIES OF OTHERS

Inspecting the unit prior to installation is the responsibility of the installer or building contractor who acts on behalf of the user. They are responsible for ensuring the unit is free of defect or damage. Notices are placed on and in the unit and on the shipping carton advising the installer of this responsibility. In the event of a problem, the unit must not be installed. The Company is not responsible for failures or damage that could have been discovered, repaired, or avoided by proper inspection and testing prior to installation.

Damage occurring in transit is the responsibility of the carrier. The user or installer MUST open the crate and inspect the unit for damage when it is delivered. If damage is discovered, it must be reported immediately to the seller and the carrier in writing, and an inspection requested. Failure of the carrier to respond should be reported to the seller and the carrier. Your freight claims should be filed promptly thereafter.

It is the responsibility of the installer, building contractor, or user to provide access for service. The Company is not responsible for any costs relating to obtaining access for repair. The user shall bear such costs and, if appropriate, must seek recovery from the installer.

Damage occurring to the unit during installation is the responsibility of the installer and/or building contractor and damage occurring thereafter is the responsibility of the user.

Failure of any optional equipment is the sole responsibility of the equipment manufacturer. (Options and accessories manufactured by the Company are warranted for ninety (90) days from the original date of purchase for parts only.)

The Distributor or Dealer is responsible for knowing local code requirements and notifying the installing contractor and/or user of these requirements at the time of purchase. The Company is not responsible for costs to modify any product to obtain any code approval, such as city, county, or state building codes in U.S.A. or municipal or provincial codes in Canada.

WARRANTY SERVICE

For the customer's benefit, the Company maintains a list of independent service personnel to perform required warranty service repairs. Such firms are not agents or representatives of the Company and cannot bind the Company by words or conduct.

The Company will provide the warranty service described above when the following conditions have been met: the failure is of the nature or type covered by the warranty; the user has informed an Authorized Jacuzzi Whirlpool Bath Service Agent or Warranty Service Department Representative of the nature of the problem during the warranty period; conclusive evidence (e.g., proof of purchase or installation) is provided to the foregoing by the user proving that the failure occurred or was discovered within the warranty period; an authorized independent service person or Company representative has been permitted to inspect the unit during regular business hours within a reasonable time after the problem was reported by the user.

In order to obtain warranty service, consult your local telephone book for the location of the nearest Jacuzzi Whirlpool Bath Authorized Service Agent. Describe the problem and the Authorized Service Agent will inspect the unit and provide the required warranty service.

If you are unable to contact a Jacuzzi Whirlpool Bath Authorized Service Agent, call or write:

Jacuzzi Whirlpool Bath
Warranty Service Department
P.O. 702168
Dallas, TX 75370-2168
Call: 1-(800) 288-4002

To obtain warranty replacement for factory-installed components for Company supplied options and accessories manufactured and supplied by the Company, call or write the above. Provide a description of the problem and proof of purchase. You will be instructed how to obtain replacements and where to return, at your expense, the failed component(s), option(s), or accessory(ies).

All replacement parts, equipment, and repairs shall assume the remaining warranty period of the part(s) replaced.

The Company's warranty obligation shall be discharged upon tender of replacement or repair. The customer's refusal to accept the tender terminates the Company's warranty obligation.

©1998 Jacuzzi Whirlpool Bath N660000 8/13/04

Ninety-Day
Parts Only
Limited Warranty
On
Accessory(ies)



Warranty Registration Card

This card must be filled out and returned to the address printed on the other side within thirty (30) days from date of purchase in order for this warranty to be come effective.
Purchaser's Name _____
Purchaser's Address _____
City _____ State _____ Zip _____

Date of Purchase _____
Model Name _____
Serial Number _____
Dealer's Name _____
Dealer's Address _____

Ninety-Day
Parts Only
Limited Warranty
On
Accessory(ies)

JACUZZI WHIRLPOOL BATH
N660000 8/13/04

1. How did you first hear about this Jacuzzi® product?
 Advertisement Article in Magazine/Newspaper
 Visited Dealer/Plumbing Supplier Yellow Pages
 Builder/Plumber/Remodeler Decorator/Architect
 Visited Retailer/Home Center Store
 Word of Mouth... Friend/Relative/Acquaintance
 Other (Please Describe) _____
2. Who first gave you specific information about this product (specifications, prices, etc.)?
 Dealer/Plumbing Supplier Builder Remodeler
 Plumbing Contractor Retailer/Home Center Store
 Decorator/Architect Already Installed
 What was the main reason for purchase?
 Styling Warranty Service Product Features
 Brand Name Price Hydrotherapy
 Home Resale _____
 Other _____
4. Who finally decided which product you would buy?
 Self Spouse Self and Spouse Together
 Other Family Member Designer/Architect
 Builder/Plumber/Remodeler Already Installed
 Who installed? Already installed/New Home
 Contractor/Plumber when remodeling
 Self/Spouse when remodeling
 Other _____
6. What is the current market value of this property?
 Please estimate \$ _____
7. What is the age of the head of the household? _____ years
8. What other manufacturers did you consider?
 Eiler Lasco Price Priser Aqua Glass
 Kohler American Standard Sterling
 Other (Specify) _____
9. How long did you shop before purchasing unit?
 1 day 2 months-6 months
 2-7 days 6 months-1 year
 1 week-2 weeks 1 year-2 years
 2 weeks-4 weeks +2 years
 1 month-2 months _____
10. Approximately how long have you lived in this home?
 Please indicate, approximately, the total annual income of your household.
 Up to \$24,999 \$50,000 to \$74,999
 \$25,000 to \$29,999 \$75,000 to \$99,999
 \$30,000 to \$39,999 \$100,000 to \$149,999
 \$40,000 to \$49,999 \$150,000 and Above
12. Was your purchase process?
 Very easy Easy Difficult Very Difficult
13. How technically aware were you of the patented Jacuzzi® jet system prior to your purchase?
 Not aware Somewhat aware Very aware