



# Neo Angle Shower System

## WITHOUT BODY SPRAY OR WITH BODY SPRAY

### INSTALLATION INSTRUCTIONS

#### BASIC COMPONENTS

- Neo Shower Base
- Back Wall
- Seat Wall (LH or RH)
- Shelf Wall (LH or RH) with accessory bracket (purchased separately, chrome or brass)

OR

- Neo Shower Base
- Body Spray Wall
- 2 Shelf Walls with accessory brackets (purchased separately, chrome or brass)

#### \*OPTIONAL FEATURES

- Optica™ Wall Mount Shower Set
- Optica™ 300 Shower Mixer Valve
- 6-Port Showerhead
- Dome (clear)
- SteamPro™ Steam Generator
- Digital Controller for SteamPro™
- Steam/Shower Door

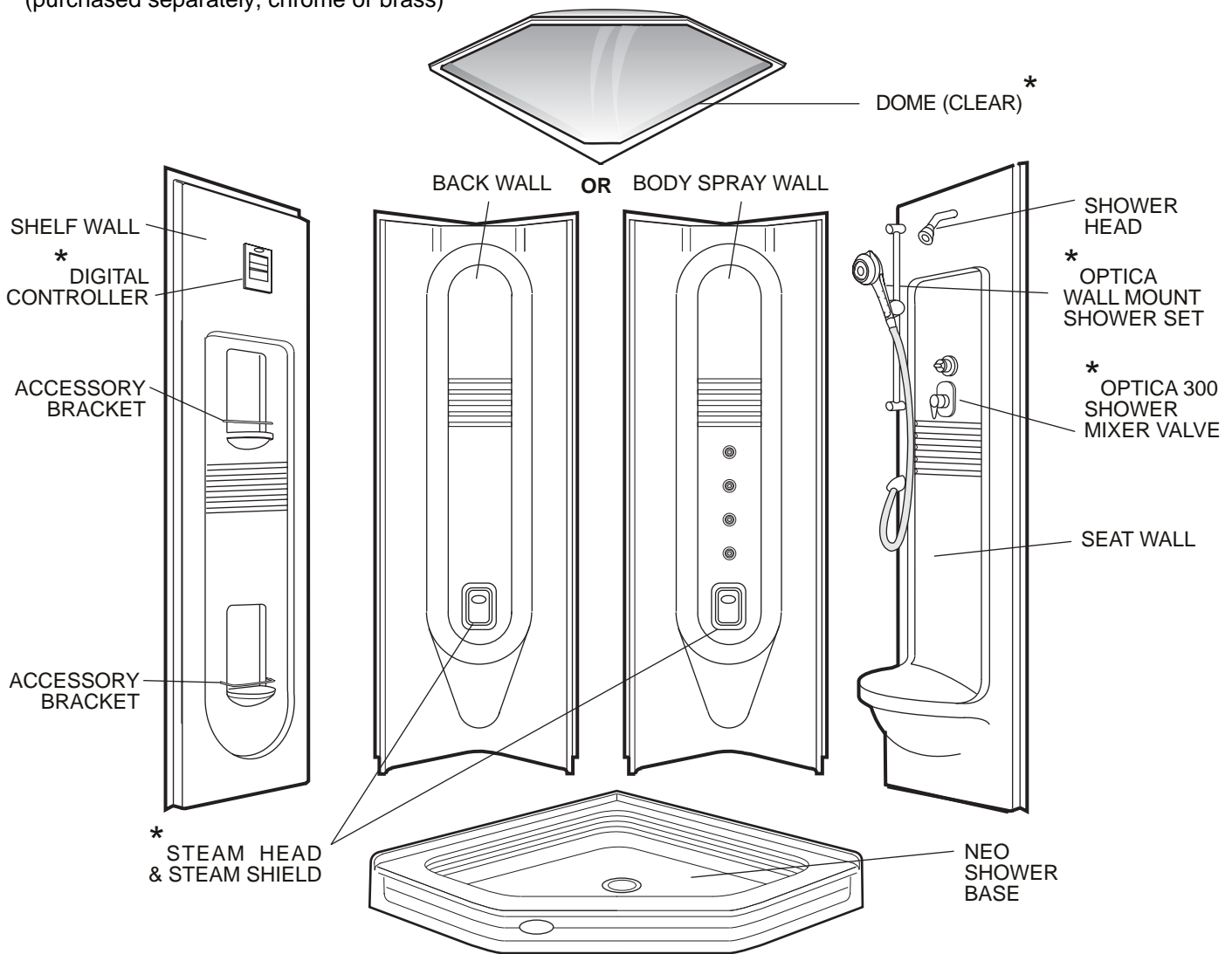

NOTE: The body spray jets require a minimum operating water pressure of 30 psi.

Illustration shown here features a right hand seat wall unit with all options.

Use installation instructions provided with product. Product specifications are subject to change without notice.

# INSTALLATION INSTRUCTIONS

**Important: Read complete instructions before beginning installation.**

**Review instructions for all optional items being considered for installation before completing rough-in. The successful installation of the options may require some modifications to be made to the custom shower system or the rough-in structure before completion.**

Check for shipping damage upon receipt of the custom shower system. Jacuzzi Whirlpool Bath is not responsible for damage sustained during shipping. If damage is evident before unpacking, see instructions regarding shipping claims on the outside of the carton and immediately file a claim with the carrier.

Once the components have been removed from the carton and before it is permanently installed, check the parts completely for damage resulting from shipping or handling. All Jacuzzi Whirlpool Bath products are factory tested for fit and finish prior to shipping. If problems are detected, immediately notify your Jacuzzi Whirlpool Bath dealer or Authorized Service Agent, or call Jacuzzi Whirlpool Bath, (800) 288-4002, for Warranty Service.

**NOTE: Damage or defects which could have been discovered and repaired prior to installation and which are claimed after final installation of the shower system are excluded from our warranty.**

## STEP 1. ROUGH-IN FRAMING DETAILS

**ROUGH-IN DIMENSION CHART**

MODEL	A	B	C	D	E	F
4242N	42-1/8"	42-1/8"	16"	16"	27"	12-3/8"
4848N	48-1/2"	48-1/8"	16"	16"	32-1/4"	16-3/8"

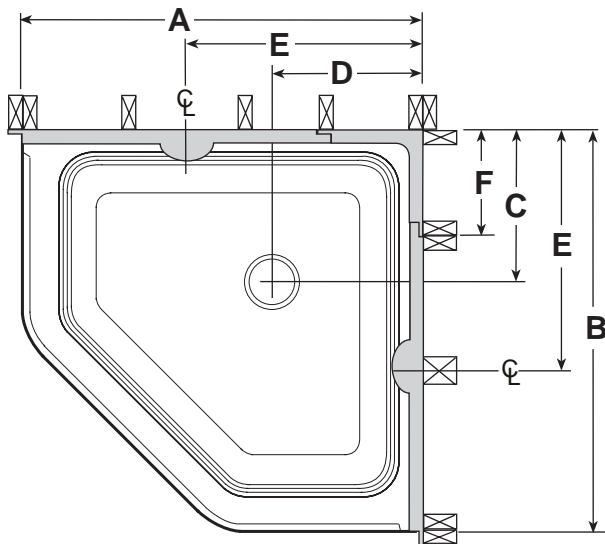

SHOWN WITH 2 SHELF WALLS

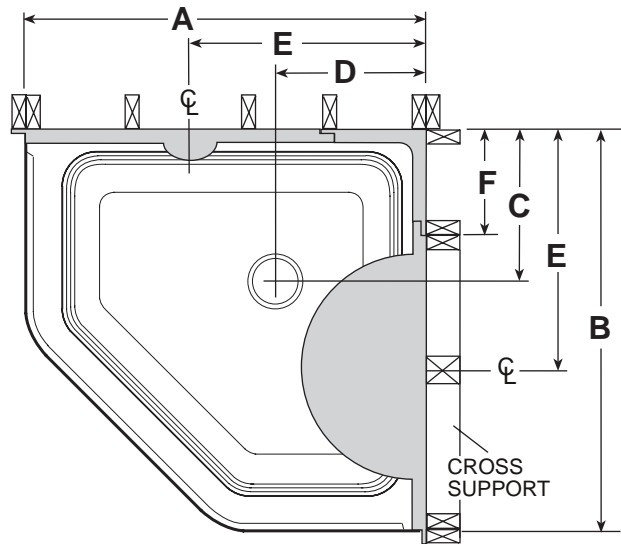

SHOWN AS A RIGHT HAND SEAT WALL

## STEP 2. ROUGH-IN PLUMBING

- Install water lines and rough plumbing. Valve should be located between 36" and 48" from the floor. Use blocking and secure with pipe straps.
- If stationary shower is used, install shower riser. Suggested shower head location is 78" from the floor (above the endwall).
- The locations of the valves, mixers, and shower head should be determined before the walls are placed in position. Where access to connections is limited, allow enough flexibility in the supply lines for easier positioning of the valves after the unit is in place.

From stable reference points such as subfloor and front of the double studs, measure and note the locations of the valves, shower head arm and connection for body spray jets.

## STEP 3

Install Shower Base per Shower Base Instructions.

- For proper fit and installation of the custom shower system it is imperative that the shower base is level on all sides and the wall structure is plumb.

**NOTE:** Watertight installation of the drain is the installer's responsibility. Drain leakage is excluded from the Jacuzzi Whirlpool Bath warranty of this product. (See "Drain Installation Instructions" provided with drain.)

## ROUGH-IN PLUMBING DETAILS

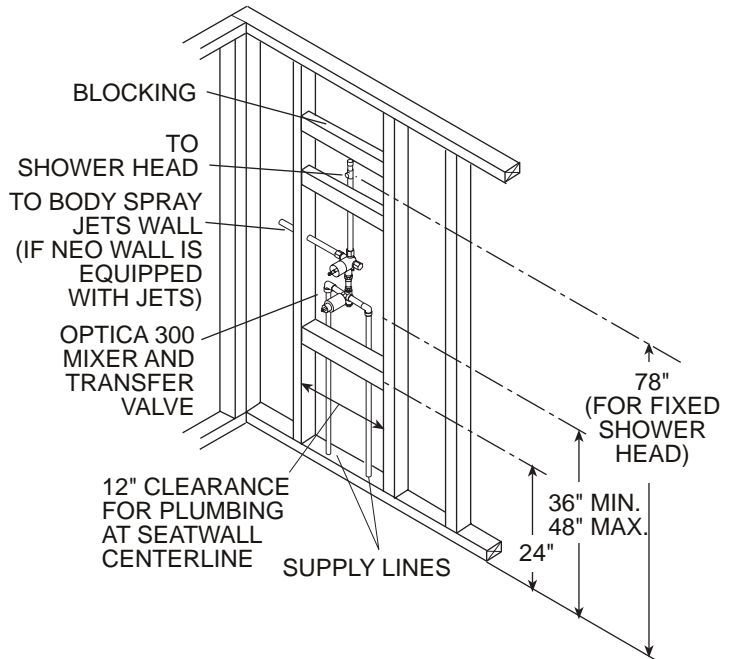

## SUGGESTED PLUMBING LAYOUT

(REVERSE FOR LEFT HAND SEAT WALL VERSION)

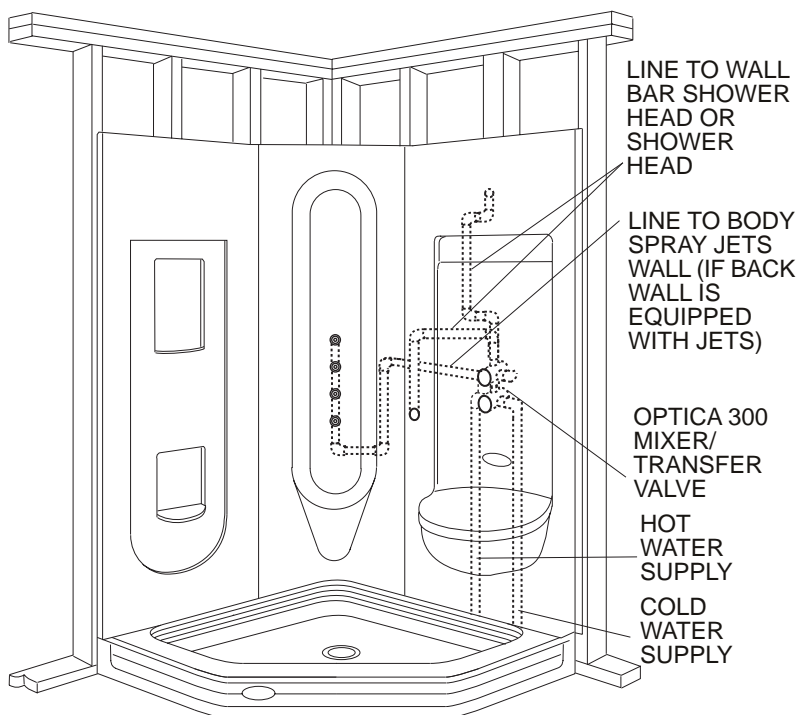

## OPTICA 300 CONNECTIONS

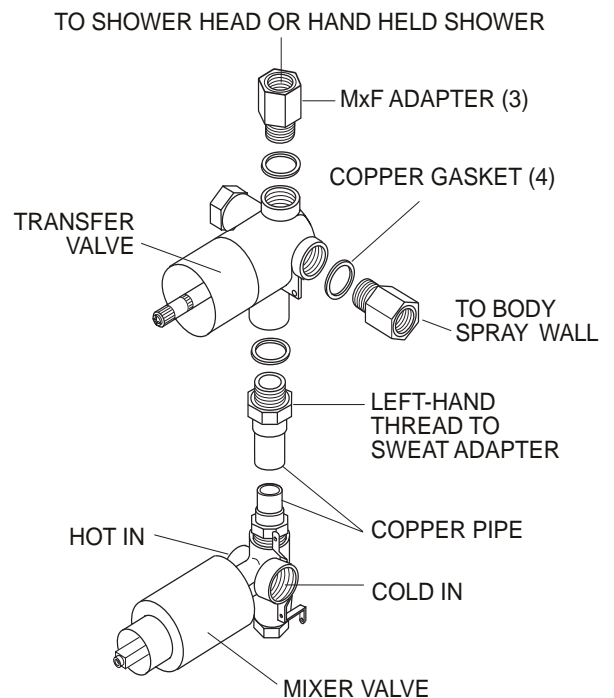

## STEP 4. BACK OR BODY SPRAY INSTALLATION

- A. Attach the pins to the wall, (5) per side.
- B. Temporarily place wall in position on the base and against the corner stud wall.
- C. Temporarily place the shelf wall and seat wall in position by engaging the pins and holes.
- D. Line up system walls and base at the front. Shim the back or body spray wall top flange if necessary.
- E. Remove all walls. Hook up plumbing from transfer valve to body spray plumbing.
- F. Place a 1/4" bead of caulking at the bottom of the shower base flange where the wall will sit.
- G. Place a 1/4" to 1/2" bead of construction adhesive on each stud where the back surface of the panel stiffeners will make contact.
- H. Place the wall in position on the shower base. Secure the top flange to the stud wall using #6 drywall screws. The wall must remain seated and flush on the shower base to ensure a matching joint to the sidewall.
- I. Secure the two side flanges to the side stud walls using #6 drywall screws. Shim between the flange and studs as required to maintain plumb walls.

## BACK WALL INSTALLATION AND DETAILS

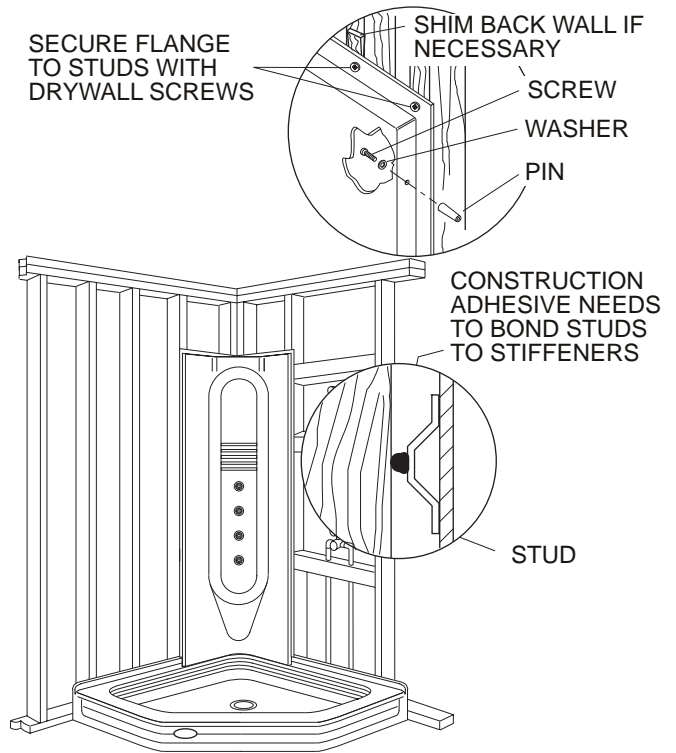

## STEP 5. SEAT WALL INSTALLATION

- A. Temporarily place the seat wall in position resting the seat wall on the base. Make certain the wall and base are in line at the front notch. Remove the seat wall.
- B. Mark valve locations on the back side of the panel if there is access. Remove the shelf wall and drill faucet/plumbing access holes as required. If there is no access for marking from behind, measure locations of the valves and transfer dimensions to wall before drilling. Protect the wall surface with masking tape to prevent scratching the wall panel before drilling.
- C. After faucet/plumbing access hole(s) are complete, repeat dry-fit to ensure a correct cut.
- D. Apply a 1/4" bead of sealant to each vertical edge and around each pin of the back wall. Apply a 1/4" bead of sealant to the shower base edge where the seat wall will rest.
- E. Place a 1/2" bead of construction adhesive at 1" centers as shown.
- F. Place the seat wall in position on the pins of the body spray wall and against the side stud wall. Secure the top flange to the stud wall using #6 drywall screws. The seat wall must remain seated flush on the shower base to ensure a matching joint to the back wall. Shim top as required to keep the panel square and perpendicular. Secure the front flanges to the side stud wall using #6 drywall screws. Shim between the flange and studs as required.
- G. Clean off excess sealant.
- H. Drill a 3/16" hole into the stud wall through the hole above the seat. Push the seat firmly against the stud wall to ensure the structural adhesive has contacted the back surfaces of the seat. Secure the seat wall to the stud wall with the 5/16" lag screw and washer. Tighten only until the washer is snug and does not move. Completely caulk and seal the lag screw and washer. After the caulking has cured, adhere the nameplate over the hole as shown.

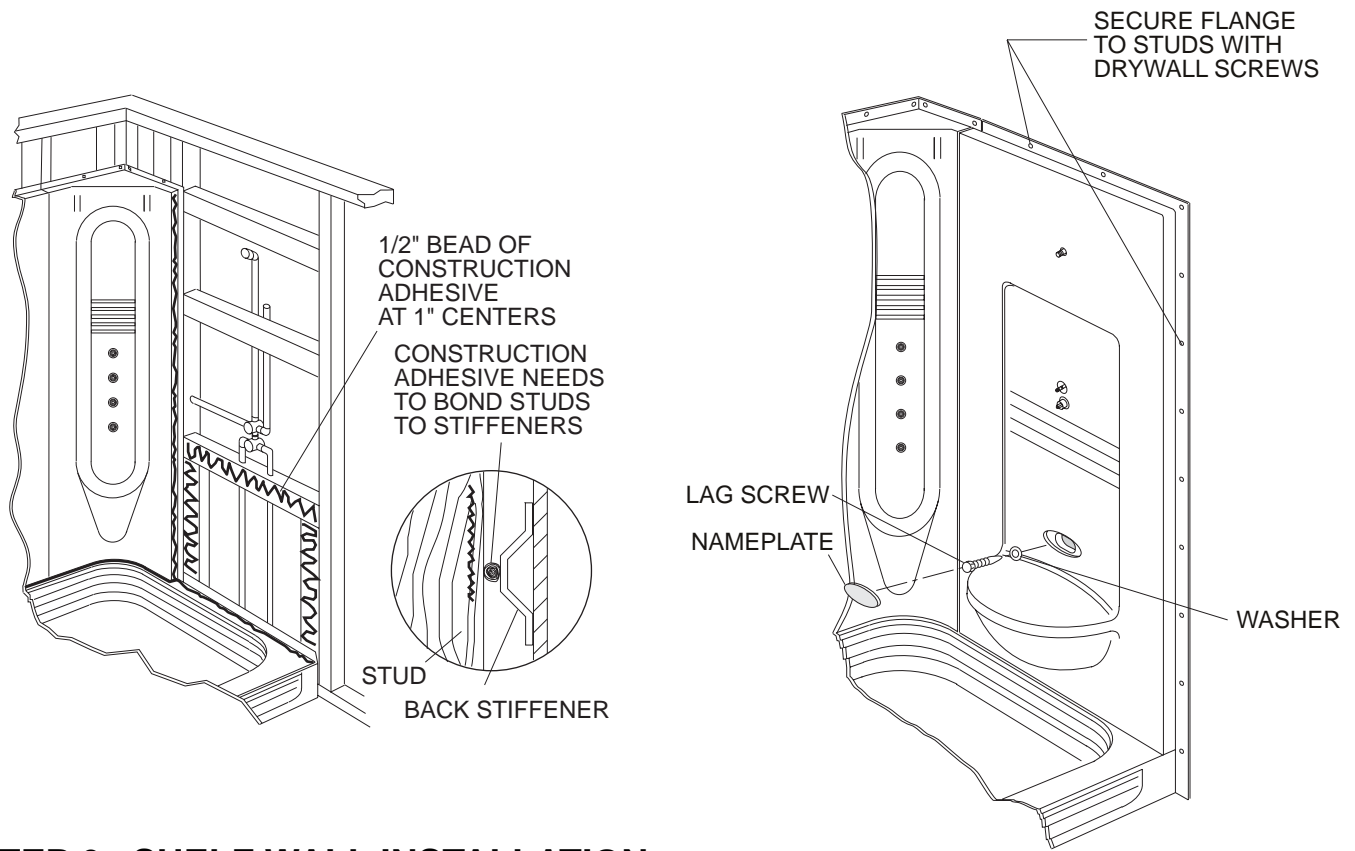

## STEP 6. SHELF WALL INSTALLATION

- A. Attach the accessory brackets to the shelf wall.
- B. Temporarily place shelf wall in position, resting shelf wall on the base. Make certain wall and base are in line at front notch.
- C. Apply a 1/4" bead of sealant to each vertical edge and around each pin of the body spray wall. Apply a 1/4" bead of sealant to the shower base edge where the shelf wall will rest.
- D. Place a 1/4" to 1/2" bead of construction adhesive at each stud where the back surface of the panel stiffeners will make contact.
- E. Place the shelf wall in position on the pins of the body spray wall and against the side stud wall. Secure the top flange to the stud wall using #6 drywall screws. The shelf wall must remain seated flush on the shower base to ensure a matching joint to the corner walls. Shim top as required to keep the panel square and perpendicular. Secure the front flange to the side stud wall using #6 drywall screws. Shim between the flange and studs as required to maintain plumb walls.
- F. Clean off excess sealant.

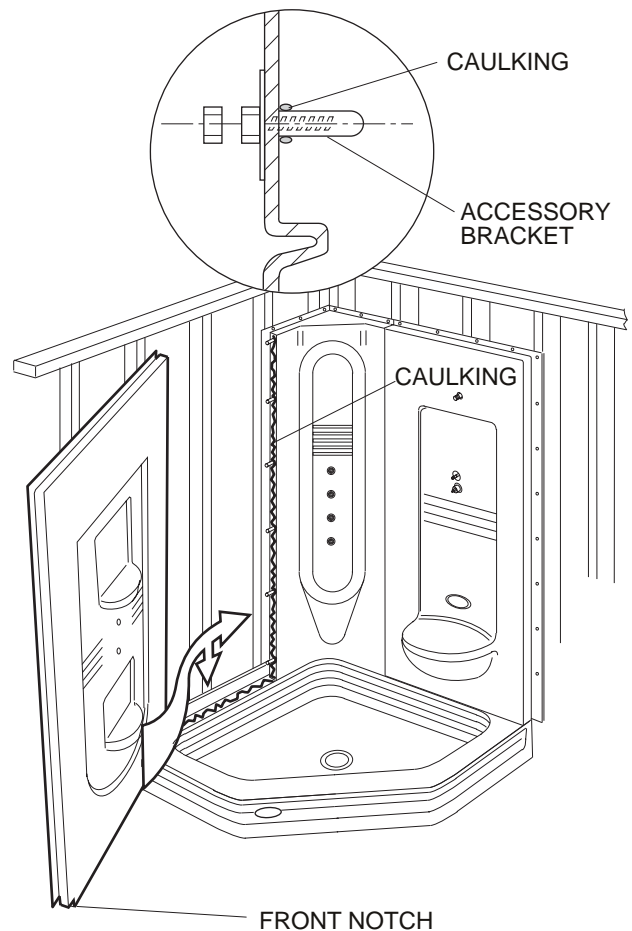

# Determining Glass Enclosure Dimensions

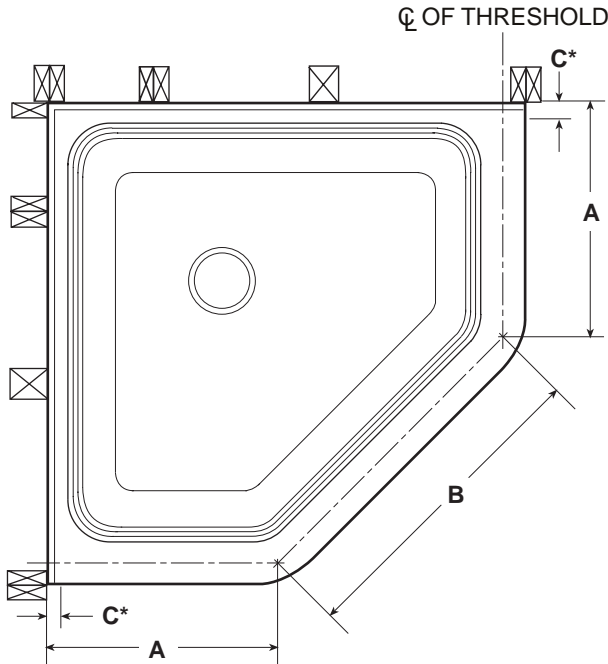

**ROUGH-IN DIMENSION CHART**

MODEL	A	B	C*
4242N	20-3/4"	27-3/8"	1-3/8"
4848N	26-3/4"	27-1/2"	1-3/8"

\*C represents the dimension from the stud wall to the face of the finishing materials used in the shower construction.

If Jacuzzi Whirlpool Bath surround walls are used, subtract 1-3/8" from dimension A to arrive at glass enclosure dimensions. If other materials are used, subtract their thickness from dimension A.

**PRODUCT SPECIFICATIONS ARE SUBJECT TO CHANGE WITHOUT NOTICE.  
USE INSTALLATION INSTRUCTIONS SUPPLIED WITH PRODUCT.**

Jacuzzi Whirlpool Bath has obtained applicable code (standards) listings generally available on a national basis for products of this type. It is the responsibility of the installer/owner to determine specific local code compliance prior to installation of the product. Jacuzzi Whirlpool Bath makes no representation or warranty regarding, and will not be responsible for any code compliance.

**Jacuzzi Whirlpool Bath**  
P.O. Box 702168, Dallas, TX 75370-2168  
**Service Support:** Call (800) 288-4002

©1997 Jacuzzi Whirlpool Bath M903000 8/13/04

# Jacuzzi Whirlpool Bath Limited Warranty

## Shower System Product

### WARRANTY COVERAGE

Jacuzzi Whirlpool Bath (the "Company") offers the following express limited warranty to the original purchaser of any Jacuzzi Whirlpool Bath Shower System product ("unit") who purchases the product for personal or single family use ("user"). The Company will repair or replace, at its option, the unit or its equipment in accordance with the following terms and conditions.

### ONE YEAR LIMITED WARRANTY ON SHOWER SYSTEM

Our warranty on Shower System products is for one (1) year. Our warranty covers the unit and factory-installed components (e.g., pump, motor) against defects in material or workmanship. Warranty coverage begins on the date the unit was originally purchased by the user.

### NINETY DAY (PARTS ONLY) LIMITED WARRANTY ON OPTIONS AND ACCESSORIES

Our warranty on options and accessories manufactured by the Company is for ninety (90) days for parts only. Our warranty covers options and accessories manufactured by the Company (e.g., fill spout kits, trim kits, skirts) against defects of material or workmanship. Warranty coverage begins on the date the option or accessory was originally purchased by the user.

### WARRANTY LIMITATIONS

Our warranty does not cover defects, damage, or failure caused by the common carrier, installer, user, or other person, or resulting from, without limitation, any of the following: careless handling (lifting unit by plumbing, abrading finish, etc.); modification of any type for any reason (including modification to meet local codes); improper installation (including installation not in accordance with instructions and specifications provided with the unit); connections supplied by the installer of the equipment; improper voltage supply or unauthorized electrical modification; misuse; incorrect operation, or lack of proper routine maintenance; operation of the unit without specified minimum amount of water or at inappropriate water temperature; use of abrasive or improper cleaners; or acts of God, such as lightning, floods, earthquakes, etc.

In addition, THE COMPANY WILL NOT BE RESPONSIBLE FOR INCIDENTAL OR CONSEQUENTIAL DAMAGES or losses arising from any cause (e.g., water damage to carpet, ceiling, loss of use, etc.) including its own negligence; damages to, respecting, or resulting from: plated parts when chemicals are used in the unit; optional equipment not manufactured by the Company, supplied by Dealer, installer or the Company; the unit's prior usage as an operational display; or defects that should have been discovered before installation. This limited warranty does not include: labor, transportation, or other costs incurred in the removal and/or reinstallation of the original unit and/or installation of a replacement unit; any costs relating to obtaining access for repair; or loss of use damage, including loss of sales, profit or business advantage of any kind under any circumstances. Units in commercial use are excluded from any warranty coverage whatsoever.

Warranty coverage is provided in the United States of America only.

### IMPLIED WARRANTIES

All implied warranties of merchantability and fitness for a particular purpose are equal in duration with the express warranties set forth herein.

NOTICE: This warranty gives you specific legal rights, and you may also have other rights which vary from state to state. There are no warranties applicable to Jacuzzi Whirlpool Bath products except as expressly stated herein or as implied by applicable state and federal laws. The Company will not be responsible for any statements or representations made in any form that go beyond, are broader than or are inconsistent with any authorized literature or specifications furnished by the Company.

Some states do not allow limitations on how long an implied warranty lasts, or the exclusion or limitation of incidental or consequential damages, so the above limitations and exclusions may not apply to you.

### RETURN OF WARRANTY CARD

The attached pre-addressed Warranty Registration Card MUST be filled out by the purchaser within thirty (30) days from purchase and mailed to Jacuzzi Whirlpool Bath in order for this warranty to become effective.



Jacuzzi Whirlpool Bath  
P.O. Box 702168  
Dallas, TX 75370-2168

## RESPONSIBILITIES OF OTHERS

Inspecting the unit prior to installation is the responsibility of the installer or building contractor who acts on behalf of the user. They are responsible for ensuring the unit is free of defect or damage. Notices are placed on and in the unit and on the shipping carton advising the installer of this responsibility. In the event of a problem, the unit must not be installed. The Company is not responsible for failures or damage that could have been discovered, repaired, or avoided by proper inspection and testing prior to installation.

Damage occurring in transit is the responsibility of the carrier. The user or installer MUST open the crates and inspect the unit for damage when it is delivered. If damage is discovered, it must be reported immediately to the seller and the carrier in writing, and an inspection requested. Failure of the carrier to respond should be reported to the seller and the carrier. Your freight claims should be filed promptly thereafter.

It is the responsibility of the installer, building contractor, or user to provide access for service. The Company is not responsible for any costs relating to obtaining access for repair. The user shall bear such costs and, if appropriate, must seek recovery from the installer.

Damage occurring to the unit during installation is the responsibility of the installer and/or building contractor and damage occurring thereafter is the responsibility of the user.

Failure of any optional equipment is the sole responsibility of the equipment manufacturer. (Options and accessories manufactured by the Company are warranted for ninety (90) days from the original date of purchase for parts only.)

The Distributor or Dealer is responsible for knowing local code requirements and notifying the installing contractor and/or user of these requirements at the time of purchase. The Company is not responsible for costs to modify any product to obtain any code approval, such as city, county, or state building codes.

## WARRANTY SERVICE

For the customer's benefit, the Company maintains a list of independent service personnel to perform required warranty service repairs. Such firms are not agents or representatives of the Company and cannot bind the Company by words or conduct.

The Company will provide the warranty service described above when the following conditions have been met: the failure is of the nature or type covered by the warranty; the user has informed an Authorized Jacuzzi Whirlpool Bath Service Agent or Warranty Service Department Representative of the nature of the problem during the warranty period; conclusive evidence (e.g., proof of purchase or installation) is provided to the foregoing by the user proving that the failure occurred or was discovered within the warranty period; an authorized independent service person or Company representative has been permitted to inspect the unit during regular business hours within a reasonable time after the problem was reported by the user.

In order to obtain warranty service, consult your local telephone book for the location of the nearest Jacuzzi Whirlpool Bath Authorized Service Agent. Describe the problem and the Authorized Service Agent will inspect the unit and provide the required warranty service.

If you are unable to contact a Jacuzzi Whirlpool Bath Authorized Service Agent, call or write:

Jacuzzi Whirlpool Bath  
Warranty Service Department  
P.O. Box 702168  
Dallas, TX 75370-2168  
Call: (800) 288-4002

To obtain warranty replacement for factory-installed components or Company supplied options and accessories manufactured and supplied by the Company, call or write the above. Provide a description of the problem and proof of purchase. You will be instructed how to obtain replacements and where to return, at your expense, the failed component(s), option(s), or accessory(ies).

All replacement parts, equipment, and repairs shall assume the remaining warranty period of the part(s) replaced.

The Company's warranty obligation shall be discharged upon tender of replacement or repair. The customer's refusal to accept the tender terminates the Company's warranty obligation.

Ninety-Day  
Parts Only  
Limited Warranty  
On  
Accessory(ies)

©Copyright 1997 Jacuzzi Whirlpool Bath M903000 8/13/04



Ninety-Day  
Parts Only  
Limited Warranty  
On  
Accessory(ies)



## Warranty Registration Card

This card must be filled out and returned to the address printed on the other side within thirty (30) days from date of purchase in order for this warranty to be come effective.

Purchaser's Name \_\_\_\_\_  
 Purchaser's Address \_\_\_\_\_  
 City \_\_\_\_\_ State \_\_\_\_\_ Zip \_\_\_\_\_  
 Date of Purchase \_\_\_\_\_  
 Model Name \_\_\_\_\_  
 Serial Number \_\_\_\_\_  
 Dealer's Name \_\_\_\_\_  
 Dealer's Address \_\_\_\_\_

1. How did you first hear about this Jacuzzi® product?  
 Advertisement  Article in Magazine/Newspaper  
 Visited Dealer/Plumbing Supplier  Yellow Pages  
 Builder/Plumber/Remodeler  Decorator/Architect  
 Visited Retailer/Home Center Store  
 Word of Mouth... Friend/Relative/Acquaintance  
 Other... Please Describe \_\_\_\_\_
2. Who first gave you specific information about this product (specifications, prices, etc.)?  
 Dealer/Plumbing Supplier  Builder  Remodeler  
 Plumbing Contractor  Retailer/Home Center Store  
 Decorator/Architect  Already installed  
 Styling  Warranty Service  Product Features  
 Brand Name  Price  Hydrotherapy  
 Home Resale  Other \_\_\_\_\_
4. Who finally decided which product you would buy?  
 Self  Spouse  Self and Spouse Together  
 Other Family Member  Designer/Architect  
 Builder/Plumber/Remodeler  Already installed  
 Who installed?  Already installed/New Home  
 Contractor/Plumber when remodeling  
 Self/Spouse when remodeling  
 Other \_\_\_\_\_
6. What is the current market value of this property?  
 Please estimate \$ \_\_\_\_\_
7. What is the age of the household? \_\_\_\_\_ years
8. What other manufacturers did you consider?  
 Eiler  Lasco  Price Plister  Aqua Glass  
 Kohler  American Standard  Sterling  
 Other (Specify) \_\_\_\_\_
9. How long did you shop before purchasing unit?  
 1 day  2 months-6 months  
 2-7 days  6 months-1 year  
 1 week-2 weeks  1 year-2 years  
 2 weeks-4 weeks  +2 years
10. Approximately how long have you lived in this home?  
 Please indicate, approximately, the total annual income of your household.  
 Up to \$24,999  \$50,000 to \$74,999  
 \$25,000 to \$29,999  \$75,000 to \$99,999  
 \$30,000 to \$39,999  \$100,000 to \$149,999  
 \$40,000 to \$49,999  \$150,000 and Above
11. Was your purchase process?  
 Very easy  Easy  Difficult  Very difficult  
 How technically aware were you of the patented Jacuzzi® jet system prior to your purchase?  
 Not aware  Somewhat aware  Very aware