

TECHNICAL SPECIFICATIONS



Riva® 6 Whirlpool Plus Bath

RIV7242 WLR 2CJ Riva 6 Whirlpool Bath, Left Hand (ES50)
 RIV7242 WRL 2CJ Riva 6 Whirlpool Bath, Right Hand (ES60)

INSTALLATION NOTES

Refer to installation instructions included with fixture before beginning installation. Please confirm product availability and specifications before commencing with any installation work.

PRODUCT SPECIFICATIONS AND AVAILABILITY ARE SUBJECT TO CHANGE WITHOUT NOTICE.

KEY DIMENSIONS

DIMENSIONS

72" L x 42" W x 20-1/2" H
 (1829 mm) L x (1067 mm) W x (521 mm) H

DRAIN/OVERFLOW

A: 16" (406 mm) B: 11-1/2" (292 mm)

CUTOUT

Template Provided Part Number: GM29000

TOTAL WEIGHT

1150 lb (575 kg) / 55 lb/sq. ft. (268 kg/m²)

OPERATING GALLONAGE

Min. 58 U.S. Gal. (220 Liters)

Max. 78 U.S. Gal. (295 Liters)

PRODUCT WEIGHT

111 lb (50.5 kg)

SKIRT MOUNTING

Not Available

ELECTRICAL SPECIFICATIONS

Requires a dedicated GFCI protected separate circuit.

Motor/Pump: 120 VAC, 15 AMP, 60 Hz.

RapidHeat™: 120 VAC, 15 AMP, 60 Hz.

HEATER (INCLUDED)

Requires a dedicated GFCI protected separate circuit.

RapidHeat™: P/N S750000

FEATURES, UPGRADES & ACCESSORIES

- Right and Left Hand Drain Location
- Accessories / Hardware:
 - Trim Kit: TheraPro Jet Rings #GU44
 - Trim Kit: AccuPro Jet Rings #GU45
 - Rotary Drain Kit, 26" Cable #8730
 - Trip-Lever Drain Kit: #X559
- Trim Kit Finishes Available:
 - (827) – Chrome
 - (826) – Brushed Nickel
 - (849) – Oil Rubbed Bronze

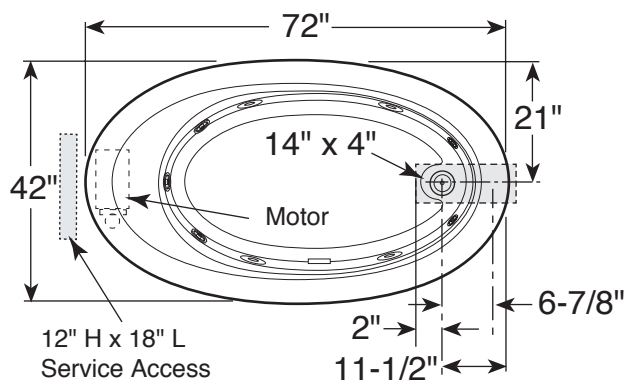

Product Shown: Riva 6 Plus Right Hand Whirlpool Bath Shown Model: ES60

* Measurements inside unit represent cutout in floor to allow for drain/overflow. Minimum Service Access dimensions given.

