

TECHNICAL SPECIFICATIONS

Signa® 5 Whirlpool Bath

SIG6042	WCR	2XX	Signa 5 Whirlpool Bath Right Pump (6880)
SIG6042	WCF	2XX	Signa 5 Whirlpool Bath Right Front Pump (DX95)
SIG6042	WCL	2XX	Signa 5 Whirlpool Bath Left Pump (C540)
SIG6042	WCG	2XX	Signa 5 Whirlpool Bath Left Front Pump (DY06)

Signa® 5 Bath

SIG6042	BCX	XXX	Signa 5 Bath (9625)
---------	-----	-----	---------------------



INSTALLATION NOTES

Refer to installation instructions included with fixture before beginning installation. Please confirm product availability and specifications before commencing with any installation work.

PRODUCT SPECIFICATIONS AND AVAILABILITY ARE SUBJECT TO CHANGE WITHOUT NOTICE.

KEY DIMENSIONS

DIMENSIONS

60" L x 42" W x 22" H
(1524 mm) L x (1067 mm) W x (559 mm) H

DRAIN/OVERFLOW

A: 17-1/2" (445 mm) B: 12-1/2" (318 mm)

CUTOUT

58" x 40"

TOTAL WEIGHT

C540, 6880, DX95, DY06: 708 lb (321 kg) / 40 lb/sq. ft. (197 kg/m²)

9625: 667 lb (303 kg) / 38 lb/sq. ft. (186 kg/m²)

OPERATING GALLONAGE

42 U.S. Gal. (159 Liters)

Max. 82 U.S. Gal. (310 Liters)

PRODUCT WEIGHT

C540, 6880, DX95, DY06: 108 lb (49 kg)

9625: 67 lb (30 kg)

SKIRT MOUNTING

Optional, U-Frame: P/N K405

ELECTRICAL SPECIFICATIONS

Models C540, 6880, DX95, DY06 only

Requires a dedicated GFCI protected separate circuit.

Motor/Pump: 120 VAC, 15 AMP, 60 Hz.

RapidHeat™: 120 VAC, 15 AMP, 60 Hz.

HEATER (OPTIONAL)

Models C540, 6880, DX95, DY06 only

Requires a dedicated GFCI protected separate circuit.

Model C540: RapidHeat™: P/N S750000

Model DX95, DY06: RapidHeat™: P/N U395000

Product Shown: Signa 5 Whirlpool Bath Right Hand Model: 6880

* Measurements inside unit represent cutout in floor to allow for drain/overflow.

Minimum Service Access dimensions given.

FEATURES, UPGRADES & ACCESSORIES

- Center Drain Location
- Accessories / Hardware:
 - Trip-Lever Drain Kit #X559
 - Rotary Drain Kit, 26" Cable #8730
 - TheraPro Jet Trim Kit: #GU44
 - AccuPro Jet Trim Kit: #GU45
- Trim Kit Finishes Available:
 - (827) – Chrome
 - (826) – Brushed Nickel
 - (849) – Oil Rubbed Bronze

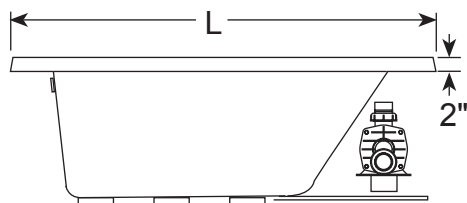
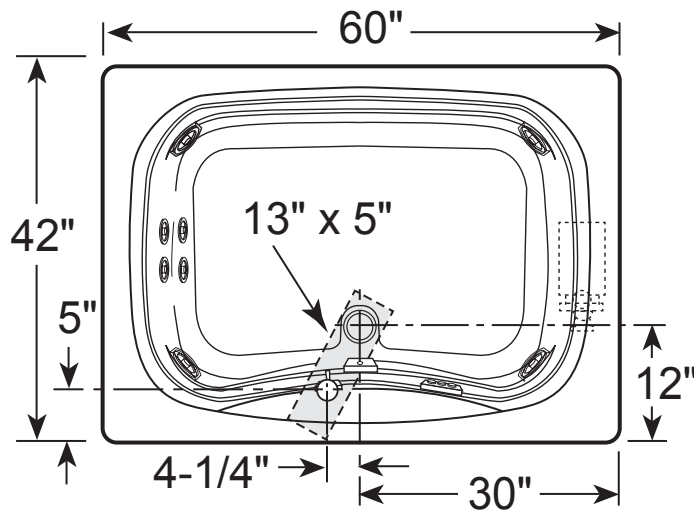

SIDE VIEW

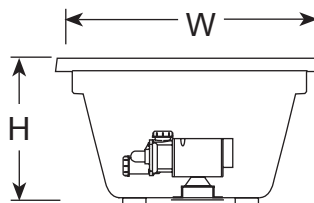

END VIEW

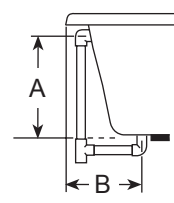

DRAIN/OVERFLOW